



Client _____ Quantity _____
 Project _____ Position _____

Smart 1400 cabinet

Model: A140/2BE

Cod: A12140600201

Technical data

Gross capacity:	1356 lt
Temperature range:	-18°-22°C
Refrigerant unit:	Plug-in
Energetic class:	C
Energy efficiency index:	49,4
Annual consumption:	2919 kW/h annum
24h consumption:	7,997 kW/h/24h
Climate class:	5
Cooling gas:	R290
Defrost:	Hot gas
Valve:	Supplied standard with solenoid
Dimensions (mm):	1480×815×2085 mm
Packing dimensions:	1575×930×2144 mm
Gross weight:	240 Kg
Voltage:	220-240 V - 50 Hz
Total rate:	1000 W
Absorbed Current:	4,6 A
Cooling capacity:	692 W*
*:	Evap. -30°C Cond. +55°C

Features

Standard equipment:	6 slides for GN2/1 shelves, 6 plastic coated GN2/1 shelves, lock with key
Control:	Electronic, display flush with the panel
Doors:	2 doors, self-closing with a 105° stop, right hinged
Door gasket:	Magnetic, triple chamber and easily replaceable
Insulation:	75 mm thickness - CFC/HCFC free
Exterior/interior finishing:	Exterior and interior AISI 304 stainless steel. Back, base and internal technical compartment in galvanized/colaminated steel.
Inner corners:	Rounded for easy cleaning and ensuring maximum hygiene
Handle:	In PVC
Racks and slides:	Stainless steel AISI 304
Feets:	AISI 304 stainless steel adjustable h 100/150 mm
Cosmo:	Predisposed for Cosmo Hub connection

Accessories and variants

- Power supply frequency 60Hz
- Other special voltage
- Half doors (4 doors) Smart
- Frame for fixed masonry plinth
- Double engine versions
- Kit für Öffnung der Tür mit Pedal
- 4 Swivel and brake castors h 128 mm
- 2 doors LED lighting
- Stainless steel shelf GN2/1
- Plastic coated shelf GN2/1
- Pair of type C slides 605 mm
- Intermediate shelf connection
- Serial interface, RS485 cable
- Cosmo connection kit

COSMO - wi-fi control

Cosmo is the wifi technology that allows Coldline appliances to be connected and monitored from a smartphone. The cabinet, connected with Cosmo kit or with Cosmo box wifi to a Cosmo hub (MODI, VISION or LEVTRONIC), can be monitored by the CosmoApp to receive alerts in case of abnormal operation.

*The installation requires a kit for the replacement of the racks

Technical draw

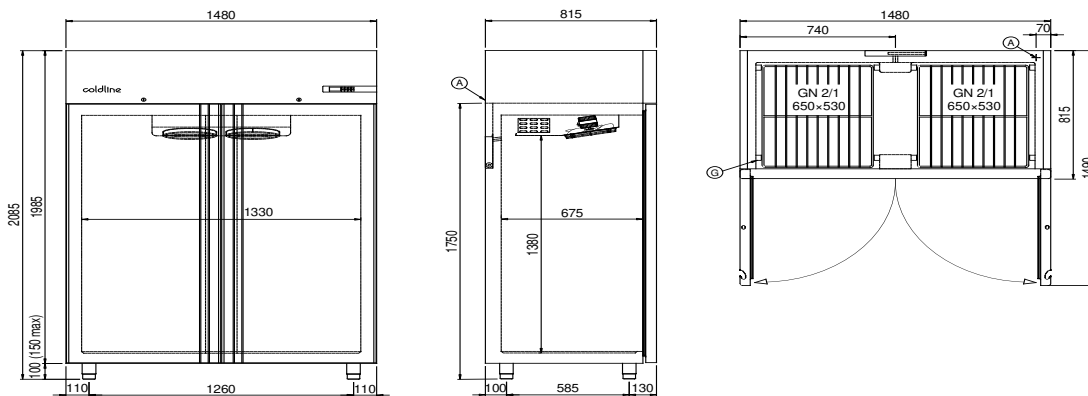

A: Power supply cable outlet

D: Airflow conveyor

G: Racks pitch

In order to constantly offer the best possible products we reserve the right to make changes on technical specifications without incurring any obligation for equipment previously or subsequently sold.