

Client \_\_\_\_\_ Quantity \_\_\_\_\_  
 Project \_\_\_\_\_ Position \_\_\_\_\_

## Smart GN counter 2 doors

**Model:** TP13/1ME-710

**Cod:** T11201000201

Smart refrigerated counter 2 doors, counter body height 710 mm, with top. Plug-in refrigeration unit, A energetic class, 5 heavy duty climatic class and R290 ecological refrigerant gas. Temperature range -2°+8°C with ventilated refrigeration. Equipment: 1 GN1/1 plastic coated shelf. Each compartment can be configured with 1/2+1/2, 1/3+2/3, 1/3+1/3+1/3 drawers. Anti-corrosion treated evaporator and hot gas defrosting. 60 mm insulation thickness - HFO with high insulation performance and low environmental impact (CFC, HCFC, HFC free). PVC handle and magnetic triple chamber door gasket, easily replaceable. Reversible, self-closing door opening with 105° stop. Interior/exterior AISI 304 stainless steel; external back and base in colaminated steel. Rounded inner corners for easy cleaning. The reinforced modular base in colaminated steel allows installation on wheels, feet, mobile or masonry plinths. Replaceable refrigerant system FSS - Fast Service System - for quick and easy service. Prepared for connection to Cosmo - wi-fi remote supervision system - and ModBus/RTU Rs485 connection.



### Technical data

<b>Top:</b>	With top
<b>Gross capacity:</b>	280 lt
<b>Temperature range:</b>	-2°+8°C
<b>Refrigerant unit:</b>	Plug-in
<b>Energetic class:</b>	A
<b>Energy efficiency index:</b>	23,3
<b>Annual consumption:</b>	527 kW/h annum
<b>24h consumption:</b>	1,444 kW/h/24h
<b>Climate class:</b>	5
<b>Cooling gas:</b>	R290
<b>Defrost:</b>	Hot gas
<b>Body height:</b>	710 mm
<b>Valve:</b>	Supplied standard with solenoid
<b>Dimensions:</b>	1300×700×850 mm
<b>Packing dimensions:</b>	1395×800×998 mm
<b>Gross weight:</b>	125 Kg
<b>Voltage:</b>	220-240 V - 50 Hz
<b>Total rate:</b>	250 W
<b>Absorbed Current:</b>	1,15 A
<b>Cooling capacity:</b>	406 W*
<b>*:</b>	Evap. -10°C Cond. +55°C

### Features

<b>Standard equipment:</b>	2 slides, 2 plastic coated GN1/1 shelves
<b>Control:</b>	Electronic, display flush with the panel
<b>Doors:</b>	2 doors, self-closing, reversible with 105° stop
<b>Door gasket:</b>	Magnetic, triple chamber and easily replaceable
<b>Insulation:</b>	60 mm thickness - CFC/HCFC free
<b>Exterior/interior finishing:</b>	Exterior and interior AISI 304 stainless steel. Back and base in colaminated steel.
<b>Inner corners:</b>	Rounded for easy cleaning and ensuring maximum hygiene
<b>Handle:</b>	In PVC
<b>Racks and slides:</b>	Stainless steel AISI 304
<b>Feets:</b>	AISI 304 stainless steel adjustable h 100/150 mm
<b>Cosmo:</b>	Predisposed for Cosmo Hub connection

## Accessories and variants

Drawers 1/2	Brackets for GN pans for drawer
Drawers 1/3	GN1/2 container + lids kit for drawer, h 150 mm
Drawers 1/3 + 2/3	GN1/3 container + lids kit for drawer, h 150 mm
Alimentazione frequenza 60Hz	Stainless steel shelf GN1/1
Other special voltage	Plastic coated shelf GN1/1
Service water sink Ø 300 mm	Pair of type C slides 505 mm
Single lever mixer hole Ø 3/4	Serial interface, RS485 cable
Adjustable feet h 145/195 mm	Cosmo cable connection kit
4 Swivel and brake castors h 128 mm	Cosmo wifi connection kit

## COSMO - wi-fi control

Cosmo is The Nice Kitchen's exclusive wi-fi technology that allows Coldline, Modular and Nevo appliances to be connected and monitored from a smartphone. The counter, connected with Cosmo kit via cable to a Cosmo hub (MODI, VISION, THAW.PRO, Levtronic, QUBI) or with Cosmo wi-fi kit, can be monitored by the CosmoApp and receive alerts in case of abnormal operation.

## Technical draw

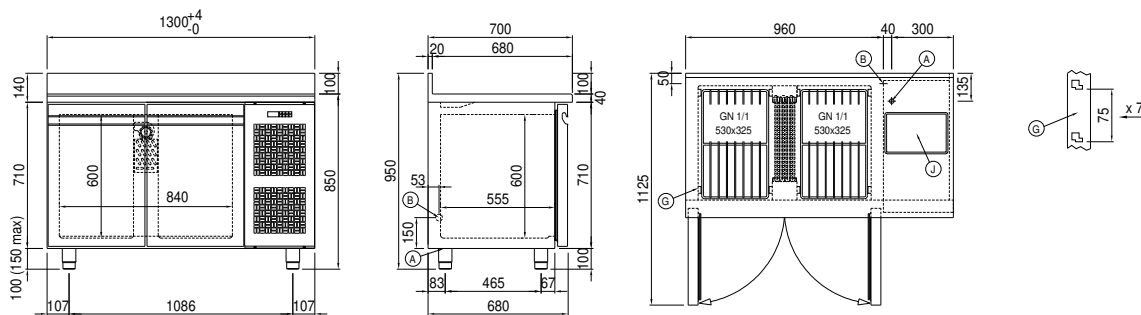

**A:** Power supply cable outlet

**B:** Condensation water drain

**G:** Racks pitch

**J:** Automatic evaporation of condensing water